

# SHOW DAILY™

The official Show Daily of IMTEX FORMING 2020

Day 6 • Tuesday, January 28, 2020



© R.J.L. Micro & Analytic GmbH

## Ecoclean - Ultra-Fast Particle Scanner

Introducing fastest method of analyzing cleaned components for Particle Sizes & Distribution.

Advantages & Benefits:

- Filter Analysis in 2.5 minutes
- Fast & Easy to use
- Absolute Robust
- VDA-19 & ISO 16232 Compliant
- Automated Report
- Maintenance Free

Live Demo

Visit Ecoclean at Hall 3A, Booth A 128

info.india@ecoclean-group.net

**ECOCLEAN**  
technology that inspires

### LASER SYSTEMS

## Creating New Avenues

Despite being on top of its industry, Meera Laser Solutions, keeps finding ways to improve its products by embracing research and development, and indulging in constant customer-centered innovation.

**Meera Laser Solutions**  
www.meeralasers.com  
Hall 2A, Booth B-115



Meera Laser Solutions' competent team at IMTEX FORMING 2020 & Tooltech 2020

**M**eera Laser Solutions (MLS) is specialised in building and integrating various laser systems for all

industrial applications. With a decade of experience, the company has established itself as a qualitative laser systems

integrator by providing solutions and machines to various industries including Automotive, Aerospace, Electronics, Medical,

Jewelry, Printing, sensor, Semiconductors, Scientific, Solar, Batteries etc.

To be continued on 4 ➡

**IS BURR A HEADACHE?**

**VALGRO INDIA LIMITED**

Meet us...

Hall 04, Booth A 132

**Valgro-Hyzer®**  
Xpert in metal preparation

---

**Valgro-Fynex®**  
superlative surface solutions

---

www.brushingmachine.com  
sales@valgroabrasives.com

**SOLUTIONS FOR** Deburring + Finishing + Edge rounding + Slug removal + Oxide removal + Surface Finishing for **SHEET METAL PROCESSING**

## About Laser Consumables

We are glad to inform that we are now Authorized Channel Partner for Centricut Laser consumables. Centricut is a Hypertherm Brand of consumables with over 3,000 part numbers, including OEM quality laser optics and mirrors, our inventory is one of the largest in the market.

With Centricut® consumables for CO2 and fiber optic laser cutting systems, you get the same quality as OEM parts, but at a lower cost. We offer more than 3,000 part numbers – one of the largest inventories anywhere – including OEM quality laser optics, nozzles, nozzle holders and accessories. All are precision-manufactured, and all come with a 100% satisfaction guarantee.



**Centricut consumables lower your cost of cutting  
and deliver excellent cut quality**

### Highest quality Products

OEM quality  
OEM approved optics  
Innovative products  
Competitively priced

### Laser cutting Expertise

Technical and  
application support  
All major OEM  
equipment supported  
Local stock  
Over 40 years'  
experience

### Consumables suitable for Major laser OEMs including

Prima®  
HSG®  
Raytools®  
Ospri®  
Wsx®  
Lasermech®

Amada®  
Bystronic®  
Mazak®  
Mitsubishi®  
Precitec®  
Trumpf®



Hall No.4  
Stall No. B-137  
January 23rd to 28th 2020  
Bangalore International Exhibition Centre

PAP/R/406 Near CG Motors Rabale, MIDC, Navi Mumbai-400708

Tel-022-41310099, Mob-7045885802 | Email ID- [info@lasertechnologies.co.in](mailto:info@lasertechnologies.co.in)

Branches - Ahmedabad | Bangalore | Delhi | Pune.



# Fiber Laser line-up



**AMADA**  
 Fiber Laser Lineup

**AMNC 3i**

Most efficient and versatile laser cutting machine

**ENSIS AJ SERIES** 3kW 6kW 9kW

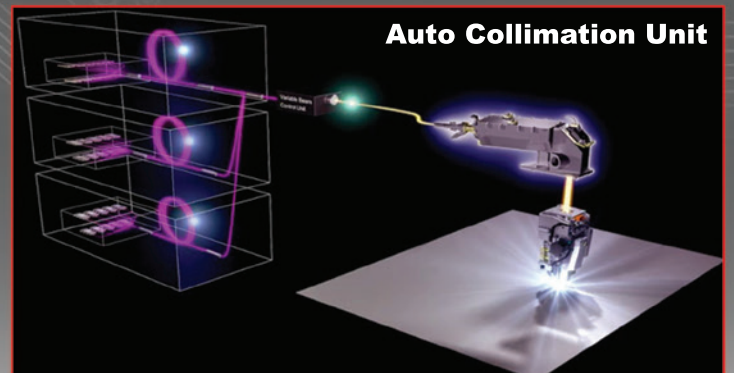

Auto Collimation Unit

**AMNC 3i**

Global standard fiber laser cutting machine

**LCG-3015AJ II** 3kW

Most suitable for startups



Hall No. 4  
 B111



**Amada (India) Pvt. Ltd.**  
 Technical and Vocational Center  
 No.60, KIADB Bengaluru Aerospace Park,  
 Singahalli Village, Budigere Post, Bangalore,  
 North Taluk – 562 129, India.  
 Ph: 080 – 71100200





Continued from 1

The company also provides customised solutions for factory automation related with CNC, Robotic system design and software for welding, cutting, assembling, testing, packaging, material handling and palletizing.

**Digitalisation is key**

Satheesh Kumar, Technical Director, Meera Laser Solutions, is enthusiastic about the role that digitalisation in processes will play in the metal forming sector. In his words, "Advanced automation and robotics, self-monitored and guided systems through artificial intelligence, that would manage the day-to-day working of the factories, will surely come. This is predicted to be the next big Industrial Revolution. Human interface would be minimum as regular processes would be largely governed, managed, and executed through artificial intelligence."

Perhaps it's for this reason that Meera Laser Solutions is offering live demonstrations of some advanced products at its booth. Kumar says, "At our booth, visitors can experience how advanced machines work and the Rol it will offer them. We are showcasing Han's Songu 6025 12KW laser cutting machine, Yueming 3015 laser cutting machine, CMA 1390 Yueming laser cutting machine (Co2), UV laser marking machine, Yueming laser marking machine, and Handheld laser welding machine." Apart from the live demo of the above machines, the company is



Satheesh Kumar, Technical Director, Meera Laser Solutions, at the company booth at IMTEX FORMING 2020.

Source: Magic Wand Media

“It is heartening to see people interested in our products. There have been fresh orders from new customers who are likely to do more business with us in the future. IMTEX FORMING has given us a good chunk of revenue and helped us immensely.”

**Satheesh Kumar**  
Technical Director  
Meera Laser Solutions

work out business with each other, all under one roof.

**Consistently innovating**

The company likes to offer customers a choice of products. For this reason, it has displayed a 12 kilowatt highly powerful cutting laser machine, one kilowatt laser cutting machine, UV laser marking and handheld laser welding machine.

Kumar, meanwhile, is bullish about the Indian economy and rues that the automotive sector must get back its mojo. However, that has not stopped the company from innovating. He says, "R&D is a strong focus area for us. We know that only through constant innovation and launches can we attract customers. There is also a dire need to offer new products at regular intervals. Approximately, we invest ₹30 to 40 lakh on R&D alone every year."

The team of Meera Laser Solutions is seeking out clients from the metal forming industry and they look forward to display their products in future IMTEX FORMING exhibitions as well.

also marketing its other products such as mould welding machine, gold welding machine, 3D gold cutting machine, railway solutions through 3D robot cutting, robotic welding, 5-axis CNC welding machine, battery welding machine, laser cladding machine, laser cleaning machine, and fully automatic industrial marking machine.

**Making a mark**

Meera Laser Solutions has developed some novel products and technologies. The company primarily focuses on automotive, railways, aerospace and as well as sheet metal industries. It has solutions for complete locomotive/train coach manufacturing. It recently introduced a product called 3D metal printing which will be pivotal for aerospace, an important sector for the company. The overall response that the company is receiving for its products at the show has been positive. "IMTEX FORMING is a

well-planned exhibition that gives us an opportunity to exhibit our expertise in creating automation solutions. We are focussing on high speed and flexibility with higher kilowatt technology, which our experienced team is showing in the live demo of our products so that customers can view it closely. The show is of immense help in promoting our new technologies, studying customer demands and analysing our market strategy," says Kumar.

"It is heartening to see people interested in our products and asking questions about the working and functioning of our exhibits. There have been fresh orders from new customers who are likely to do more business with us in the future. IMTEX FORMING has given us a good chunk of revenue and helped us immensely," he adds. For him, the expo is a wonderful platform where people from different backgrounds and industries can

**MANUFACTURING QUIZ**

**Manufacturing Quiz Wizards @ BIEC**



Quiz Winner & Runner-up Group



Quiz Winner Certificate



Quiz Winner Trophy



Quiz Runner-up Certificate



Quiz Runner-up Trophy

Source: Magic Wand Media



**POWER PRESSES**

**Singhal Power Presses Pvt Ltd**  
www.sewpresses.com  
Hall 2A, Booth B-101

## Innovations that Add Value

Harmeet Singh Chawla, Director, Singhal Power Presses Pvt Ltd has a great feeling about participating in IMTEX FORMING 2020. With plenty of footfalls, clients have come over from all across India and the company has received plenty of inquiries.

“Once the market improves and situation gets better these queries will be very fruitful. The foot falls in IMTEX FORMING 2020 has surpassed our expectation as we didn't expect this kind of impressive response,” Chawla adds.

He feels that he is going to see a good conversion rate. For him, IMTEX FORMING 2020 is a great platform where they get to meet their existing clients. SEW is a flagship company of IS Chawla Group of Companies established in 1950 at

Mumbai to offer precision and quality industrial machinery at reasonable values. It has set up its own manufacturing unit at Rajkot in 1989, a workshop machinery hub in India. The company holds a unique position in the sheet metal forming industries. It offers metal forming, cutting, blanking, piercing, stamping solutions that are reliable and stable in value. Using innovative technologies, it strives at enhanced cost-effectiveness and even higher efficiency.

SEW has a full-fledged state-of-the-art in-house manufacturing facilities that are equipped with highly accurate machinery, which ensures reliability/inter-changeability and availability of components even after a long period.



Source: Magic Wand Media

**METAL 3D PRINTERS**

**Intech Additive Solutions Pvt Ltd**  
www.intech-dmls.in  
Hall 4, Booth B-149

## First of its Kind

Intech Additive Solutions is a Bangalore based company with branches in the US and Europe and is backed by over 3 decades of manufacturing and metallurgical expertise.

Intech Additive Solutions is displaying iFusion — the first indigenously built Indian machine primarily for the medical sector, R&D labs and metal forming industry. The machine has been launched at IMTEX FORMING 2020. It is a metal 3D printer with a bed size of 144 mm dia. and can reach up to 188 mm height. "This machine can work with alloys like inconel, titanium, stainless steel, copper etc and has a 700W laser,"

says Hitesh Vishwanath Bangera, Assistant Manager, Sales & Service, Intech Additive Solutions.

### Benefits galore

The iFusion series of Metal 3D Printers, based on the Selective Laser Melting technology and the first of its kind in India, are designed for high precision, stability, reliability and to deliver unmatched performance with higher build rates. These cost-effective machines are part of Intech's 3D eco system with softwares bundled in for machine parameter optimization and build process being sold as a package. The overall target of Intech is to reduce the cost of acquisition, cost of operations and First Time Right with a quick Go to Market.



Source: Magic Wand Media

**PARTS CLEANING MACHINES**

**Ecoclean Machines Pvt Ltd**  
www.ecoclean-group.in  
Hall 3A, Booth A-128

## EcoCtwin, Twin Chamber Cleaning Machine

The machine is suitable not only for removing oil and emulsion from mass-produced parts, but also for the fine cleaning of assembly parts.

The EcoCtwin cleaning system is a low-cost, highly efficient system which, owing to its modular design, can be used for a very wide range of applications in cleaning parts with 50 percent less

cycle time. Depending on the features installed, the EcoCtwin is suitable not only for removing oil and emulsion from mass-produced parts but also for the fine cleaning of assembly parts.

### Two chambers, an advantage

All the cleaning stages are divided into two categories and use an immersion process and aqueous media. Removal of large quantities of swarf from mass-produced parts and particles of dirt with a defined size in fine cleaning can be achieved by selecting the appropriate filtering system and other application-dependent optional extras. Different types of optional equipment make it possible to use the EcoCtwin cleaning



Source: Ecoclean Machines Pvt Ltd

system in numerous areas of metal processing. The special feature of this machine is its two chambered cleaning system, which reduces the cycle time by 50 percent.





**Indian Machine Tool  
Manufacturers' Association**

WHAT HAPPENS  
WHEN THE **BIGGEST** AND  
MOST **INNOVATIVE** MINDS IN  
THE **AUTOMATION** WORLD  
COME TOGETHER?

## SYMPOSIUM ON SMART AUTOMATION

November 2020 | BIEC | Bangalore

**FOR BRANDING OPPORTUNITIES, CONTACT :**  
**Mahesh G - Email: gmahesh@imtma.in, Tel : 080 - 66246716, Mob : 9845392382**  
**Vilas G V - Email: vilas@imtma.in, Tel : 080 - 66246715, Mob : 9611026969**



# i2 Academia Pavilion Award Ceremony @ BIEC



Source: Magic Wand Media

V Anbu, Director General & CEO, IMTMA delivering key note address at the i2 Academia Award Ceremony



Source: Magic Wand Media

**First Prize** – MIT, Art Design and Technology University, Pune  
Parametric Design and Comparative Analysis for a special purpose Flexure Spring



Source: Magic Wand Media

**Second Prize** – NMAN Institute of technology (Centre for Welding Technologies), Udipi  
Two Axis tid welding of Aluminum Alloy with synchronized palrating wire Feeder



Source: Magic Wand Media

**Third Prize** – Dr V DKarad NIT World of Peace University, Pune  
Ultra Thin Sheet Metal Micro Forming



Source: Magic Wand Media

**First Consolation Prize** – Acharya Institute of Technology, Bangalore  
Low Cost 3D Printed Functional prosthetic hand



**Second Consolation Prize** – Sri Krishna College Technology, Coimbatore  
Analysis of Bead Geometry of Hard Facing Low Carbon Steel Using GNAW

## MSME CORNER



Source: Magic Wand Media

“We are into Laser machine manufacturing. The number of visitors at IMTEX FORMING is incomparable to any other machine tool exhibitions in India. In the last couple of days, the number of footfalls has come to 700. The exhibition is not only for selling, it is also a powerful platform for branding too. MSMEs are one of the biggest contributors to our GDP. As far as laser technology developers are concerned, our competition is mostly with Chinese manufacturers who get good incentives from their government. Still there are Indian customers who want to buy from the Indian manufacturers only but the price difference is too high. If the government does something to bridge the gap, Indian MSMEs will be benefited to a great extent.”

**Hitesh Parikh**  
Director – Marketing  
Agile Machineries Pvt Ltd  
www.agilelaser.com  
Hall 2A, Booth: A-104



Source: Magic Wand Media

“IMTEX FORMING is one of the biggest platforms of our country and, hence, we make it a point to participate in the show on a regular basis. The response we have received here has been extremely positive, and it just keeps getting better with every edition. We request the government to assist us in our growth in India and on foreign shores. Our company comes within the norms of the Labour Act. It would be of great benefit to us if our labour (25 currently) were provided with much more facilities. Then we can employ more people and our company can grow at a better rate.”

**Reshma R Jain**  
Proprietor  
Marvel Abrasive Tools  
www.marvelabrasivetools.com  
Hall 3A, Booth: B-136



Source: Magic Wand Media

“IMTEX FORMING platform has been of great benefit to us. Many potential customers have approached us in these days, and the overall response that we have received so far is amazing. We look forward to more leads and more business. We take the benefit of this medium and appeal to the government if it could come up with some policies for MSMEs' financial back up. This will help us focus more on our business and innovation.”

**Amol Varpe**  
Fixture Analyst  
Dhuru Engineers  
www.fixto.in  
Hall 3A, Booth: A-131

## DIGITAL FACTORY IN ACTION



**IMTMA Technology Centre**  
Indian Machine Tool Manufacturers' Association  
www.imtmatraining.com

**Live Demo  
@ IMTEX FORMING  
2020**

**“Implementing  
Industry 4.0 in Manufacturing”  
@ IMTMA Technology Centre**

**Schedule:**  
Each day from 24.01.2020 to 28.01.2020  
Session 1 : @ 11:00 am  
Session 2 : @ 03:00 pm

Live demo of data capturing and analysis in a 'Digital Factory' setup:

- Smart CNC Machine enabled with sensors
- Traceability during the entire manufacturing cycle
- Production Analytics - OEE, Idle time analytics etc.
- Quality Analytics
- Predictive maintenance based on live data



**PLATE ROLLS & ANGLE ROLLS**

**DAVI - Promau S.r.l**  
www.davi.com/in/en  
Hall 2A, Booth B-120

## Making the Right Moves

Michael Mazzola, Area Manager – Middle East & South Asia, DAVI - Promau S.r.l, is well-versed with the Indian market.

Having had a presence in India for the last 20 years, Michael Mazzola is no novice to the market here. DAVI Italy (Plate Rolls and Angle Rolls) is focusing on the following sectors in the Indian market: Process Industry, Power Sector – Thermal & Wind Energy, Infrastructure, Construction Equipment manufacturers, and Heavy and light duty fabricators. The company's Indian agent –

Batliboi Ltd has stood by DAVI for two decades. He says, "DAVI strongly believes in the Indian market. There is much learning here. It helps that we have a history of listening to customers and simultaneously achieve the best skills in bending process. This is the reason why the design of our machines constantly improves to meet customer needs."

**A new high with technology**

Mazzola is happy that Indian customers recognize and prefer DAVI's technology over other existing. He shares, "Selecting a DAVI machine might appear a higher investment, but customers can see ROI in a very short period due to high productivity and quality output."



Michael Mazzola, Area Manager – Middle East & South Asia, DAVI - Promau S.r.l at the company booth

Source: Magic Wand Media

**INDUSTRIAL EQUIPMENT SUPPLIER**

**Chennai Metco Pvt Ltd**  
www.chennaietco.com  
Hall 3A, Booth A-123

## Maintaining a Strong Tempo

C Renganathan, Director, Chennai Metco, is sure that the auto sector will bounce back faster than anyone thought.

Chennai Metco provides equipment for engineering companies mainly in the automotive sector. What it does is offer import substitutions so that customers from India can have the equipment at a reasonable price.

The team is aware that visitors want to see new and innovative products at IMTEX FORMING. The company is displaying the oscillating abrasive cutting machine, a new mounting machine and also a new automatic

polishing machine. The response from visitors has been relatively good, says Renganathan. "We were a bit nervous that with the slowdown in the automotive industry, we wouldn't see a warm reception. We have been surprised. Customers came specifically looking out for our products," he adds.

**Strong R&D**

Renganathan attributes the innovation to his R&D department without whom the production and innovation of new equipment would not be possible. He says that his company invests ₹1crore for the working of this department. "Our main clients are from India, and there has been a global slowdown in which India has also been affected especially the automotive sector. I am sure that things will get better in the near future," he says with a smile.



C Renganathan, Director, Chennai Metco at the company booth

Source: Magic Wand Media

**SPEECH SOFTWARE**

**Beckhoff Automation Pvt Ltd**  
www.beckhoff.com/twincat-speech  
Hall 3A, Booth A-121

## TwinCAT Speech from Beckhoff

Speech input and output capabilities of the software simplify plant operation and maintenance.

The human body has evolved into what could be called a system of perfectly harmonized functional units. The same applies in a figurative sense for an automation system, which combines the functions of intelligence, sensors, motion

control and vision in perfect harmony. Now with the introduction of TwinCAT Speech software, automation systems can also learn to hear and speak. TwinCAT enables automation systems to operate as efficiently and smoothly as the human body: an Industrial PC with a TwinCAT

runtime provides the 'intellectual capacity', TwinCAT Motion Control ensures precise, dynamic movements, and I/O interfaces connect to the most varied sensors and bus systems to supply information. More recently, visual abilities have been added with TwinCAT Vision as a fully integrated component. With the new TwinCAT Speech software module, listening and speaking capabilities now complete the analogy with the capabilities of humans.

TwinCAT Speech allows multilingual input and output of queries or information in line with industry standards. This enables interaction with the automation system to be carried out much more efficiently and conveniently. The technology can be applied across numerous industries in a wide range of applications from machine design to building

automation. When working on a machine component, for instance, operation and maintenance personnel can simply inquire about the impact of changed settings on the current control or simulation application without having to use a conventional operator interface. In addition, appropriate alarm messages can be given out acoustically when critical system values are reached. Speech input is available as an offline function and is implemented on the basis of built-in Windows operating system functionalities. In other words, it is accomplished without requiring an Internet or cloud connection. Speech output from TwinCAT Speech is available both as an offline function and an online function. In the case of offline, support is provided by the appropriate Windows functionalities and in online cases via Polly, the text-to-speech service from Amazon. The realistic sounding speech output for these applications is synthesized with the aid of deep learning technologies. Multiple voices can be supported in addition to the caching of audio files generated online.

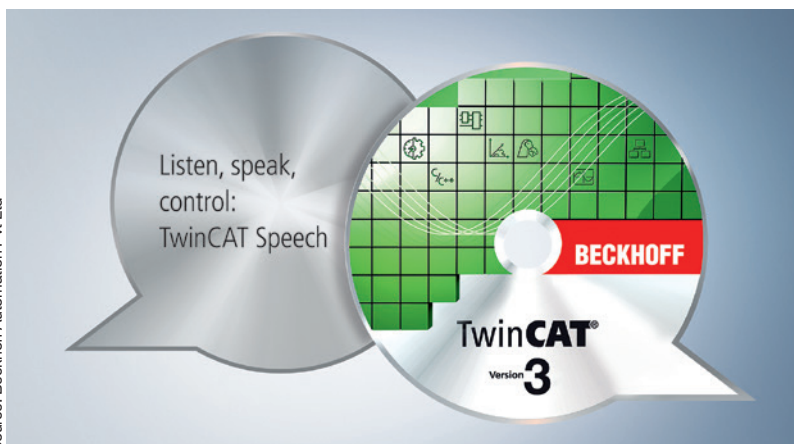

TwinCAT Speech software from Beckhoff enables the control system to listen and speak, supporting operation and maintenance personnel through convenient speech input and output channels.

Source: Beckhoff Automation Pvt Ltd



**E-BRAKE TECHNOLOGY**

**SafanDarley B.V.**  
www.safandarley.com  
Hall 4, Booth C-138

**Providing a Differentiated Experience**

An interesting read on how SafanDarley's E-Brakes led to Prime Lasers and Spiro Packs' delight.

Prime Lasers is a wholly-owned division of Primepack Container Pvt Ltd which produces Paper Tubes and Packaging material. In 2008, the company decided to set up a new factory for sheet metal fabrication. This was to be its first experience of buying sheet metalworking machinery and, unfortunately, some poor advice led it to order a 4m x 200Ton machine from a local manufacturer.

Having suffered a year of breakdowns, poor quality and general unreliability of the machine and the machine supplier, the company now needed to address these issues to be able to win new business. PD Malpani, Managing Director, Prime Lasers, contacted Darley Engineers India for help.

**Solution offered**

Darley Engineers India recommended Darley Press Brakes and gave

Prime Lasers reasons why Darley machines would give decades of excellent production without problems. After getting convinced, the company ordered an EHP 230.42/37CL machine in 2010, which was installed in early 2011. For the next 3 years of trouble-free, high-quality production, in 2014 the company felt the need for an additional press brake and contacted Darley again. This time it became one of the first companies in India to buy a SafanDarley E-Brake 100Ton - 3100 fully electric press brake.

The major benefits of the E-Brake technology, invented and patented by SafanDarley, are the elimination of hydraulics, faster cycle times,

very low energy costs, almost maintenance free and the most user-friendly windows-based touch screen control system.

**E-Brake 300-4100 Dual Drive**

The advantages of the E-Brake have proven to be so apparent and so convincing, that when they wanted to buy a 400Ton 4 m machine for its new company, Spiro Pack. The company actually reconfigured its requirements to 300T 4 m so that it could take full advantage of the new, patented E-Brake 300-4100 Dual Drive. The machine was ordered in 2018 (installed Jan 2019).

Spiro Pack exports 30-40 percent of its products to European markets. One of its Swiss customer noticed an increase in the accuracy of the products shipped to them. Prime Lasers informed it of its shift to the E-Brake. The Swiss customer naturally asked to continue the production exclusively on the E-Brake and also increased the ordered quantity.

Prime Lasers and Spiro Pack look forward to many more years of high-quality, trouble-free production on their SafanDarley E-Brakes.

**Challenge:**

Prime Lasers needed a reliable machinery for sheet metal fabrication after having suffered a year of breakdowns and poor quality with a machine brought from a local manufacturer.

**Solution:**

EHP 230.42/37CL Press Brake from SafanDarley that led to elimination of hydraulics, faster cycle times, and very low energy costs. This was followed by Spiro Pack opting for E-Brake 300-4100 Dual Drive.



Spiro Pack Personnel with SafanDarley E-Brake 300-4100

**LASER WELDING SYSTEMS**

**Coherent Laser India Pvt Ltd**  
www.coherentlaserindia.com  
Hall 2A, Booth E-101

**With a Coherent Strategy**

Dr Lalit Kumar, Managing Director, Coherent Laser India, reveals how cutting-edge technologies can shape the future of manufacturing.

The metal forming industry is seeing novelty. As an exclusive distributor for Coherent Inc. in India, Coherent Laser India Pvt Ltd offers high-class systems for applications like cutting, marking, welding, 3D printing, engraving, cleaning, etc. Coherent Laser India is showcasing an indigenously built laser welding system with rotary axis for welding of metals, dissimilar materials and various automotive parts like gears, etc. It has a small footprint but is driven by high power (2.5kw) Coherent made fibre laser.

The other system on display is a laser cleaning system, a modern hi-tech product for surface cleaning. It is a 100w fibre laser with a wide variety of applications like rust removal, deburring, die mould cleaning, and paint removal.

**Knowing the 'CREATOR'**

Advanced technology adoption is making lives of manufacturers and users easy. For example, the company's metal 3D printer namely the CREATOR comes with cloud manufacturing.

Dr Kumar says, "Cloud manufacturing solution brings greater productivity and efficiency to CREATOR 3D printing range through intelligent use of data. CREATOR users have unprecedented access to their machine(s), made possible by a dedicated tablet for real-time control of the machine's parameters, enabled by a secure cloud server and infrastructure."



Coherent Laser India booth at IMTEX FORMING 2020

**COIL PROCESSING LINES**

**RadCAM Technologies Pvt Ltd**  
www.Radcamtechnologies.com  
Hall 4, Booth C-116

**EkiControl from RadCAM**

The coil processing lines help save time, reduce scrap, reduce material movement, and increase product accuracy.

EkiControl Coil Processing lines are essential in the journey towards shop floor automation and scrap saving environment. It impacts the prevailing sheet metal fabrication technology, through upgrading in order to increase the efficiency of production starting from coil, using the solution provided by EkiControl like cut-to-length lines, slitting lines, multi-blanking cutting lines, combinate cutting lines, coil feeding handling lines, lines with special requirements, with internal punching, profiled

and peripheries such as uncoilers, loading carts, straighteners, levellers, static shears, flying shears, stacking tables, packaging tables, etc.

The lines help save time, reduce scrap, reduce material movement, increase product accuracy, etc. With EkiControl Coil processing lines, Laser/ TPP/ Presses have continuous material inflow, which increases overall efficiency of the organization. EkiControl Coil feeding and handling lines can be customized as per the production capacity.



Source: RadCAM Technologies Pvt Ltd



**MOTION CONTROLLER SYSTEMS**

**Hiwin Technologies Corp.**  
www.hiwin.tw  
Hall 4, Booth B-105

## Seeking a Larger Playing Field

Maurice Chang, Assistant VP, Hiwin Technologies Corp, has many things to be proud of, starting with unique products.

Hiwin Technology Corporation manufactures motion controller systems and has built a reputation as one of the largest suppliers in the world. It has a wide array of products such as the new electric gripper equipment, integrated electric gripper and many more. It also manufactures robots and has a series of equipment such as Scara robot, Wafer robot for semi-conductors, among others.

### Turning heads

On the other hand, its sister company, Hiwin Mikrosystem solely focuses on electrical products like torque motors, rotary table, etc. Chang considers the company to be a global leader in motion control system including rotating, precision, partitioning, robotics and motion and drive control.

India is an important market for them as they have a large base of customers here. Chang says the response at IMTEX FORMING has been overwhelming. For Hiwin the show is an opportunity to display its new and innovative products as well as interact with prospective customers and build new business relations.



Source: Magic Wand Media

**PLASMA TECHNOLOGY**

**Hypertherm (India) Thermal Cutting Pvt Ltd**  
www.hypertherm.com  
Hall 4, Booth C-102

## Cutting it Clean

Marco Mostert, Regional Director EMEA, Hypertherm Europe is happy that visitors are able to see the unmatched performance of X-Definition plasma technology during live cutting demonstrations with the XPR170 at Hypertherm's stand.

Hypertherm's X-Definition plasma is the newest form of plasma technology, building on high definition plasma and setting new standards for cut quality on mild steel, stainless steel, and aluminum. The result is squarer cut edges, markedly less angularity, and excellent surface finish on non-ferrous metals like aluminum and stainless steel. The Powermax45 XP delivers 6.5kW of output power, allowing it to cleanly cut metal up to 16mm, and sever

material nearly twice that thick. It's the most powerful and versatile tool in its class to cut, gouge and mark. Applications shown in the stand include fine feature cutting, extended reach cutting, flush cutting, gouging and marking. The company is also featuring its CAM nesting software line, automation products as well as torch and consumable technologies.

### Mission behind

Mostert says that whether it is plasma, waterjet or any other technology, their mission is to provide each customer with optimum cutting solutions that meets business needs. Several of its partners are also demonstrating the latest technological innovations including the company's X-Definition plasma technology and its Powermax air plasma systems.



Source: Magic Wand Media

**DIE TRANSPORTERS**

**Güthle Pressenspannen GmbH**  
www.guehle-swt.de  
Hall 3A, Booth B-125

## DILOS Truck and Buggy from Güthle

This logistics system for dies, devised by Güthle, embraces the handling, clamping, maintenance and storage of dies.

The trademark DILOS stands for Die Logistics System. DILOS truck and buggy have been specially designed for the needs

and high demands of pressworking shops. Emphasis has been placed on safety functions, in addition to speed of function and ergonomic operation.

The heavy weight of the dies places extraordinary demands on the design of the DILOS TRUCK and DILOS BUGGY. The dimensioning of the components and their construction is accordingly robust. **Front loading technology:** The front loading technology with the adjustable fork height permits safe changing of the dies at different presses with different heights of press bed. It can also be used to store dies in appropriate racks.

**Modular type structure:** DILOS TRUCK and DILOS BUGGY are

based on a basic, modular design. The DILOS construction kit with its series-proven components offers many functions that can be combined as needed. There are proven modules available for practically all requirements and functions.

**Docking of the carrying fork at the press bed:** For safety reasons, a firm connection between the DILOS TRUCK or BUGGY and the press bed is essential. This is also true when transferring dies to storage racks or to servicing or pre stage tables.

All these 'docking stations' are therefore fitted with a coupling bar. The carrying fork has an integrated fixing coupling, which engages when the fork is lowered onto the coupling bar. **Chassis and steering of the DILOS TRUCK:** The body

of the DILOS TRUCK is constructed as a three-wheeled sub-frame.

All versions of the DILOS TRUCK are fitted with electronic all-wheel steering. The program-controlled swivelling of all three wheels permits various movements, even turning on the spot.

**Joystick control:** The DILOS TRUCK is equipped with a portable operating panel for steering the vehicle and for controlling the die-changing functions.

A joystick allows delicate control of all movements. The monitor indicates the attitude of the wheels, which is important because the wheels are out of sight.

The DILOS Buggy is used for dies weighing 20kN to 30kN and the DILOS Truck for dies 40kN to 250kN.

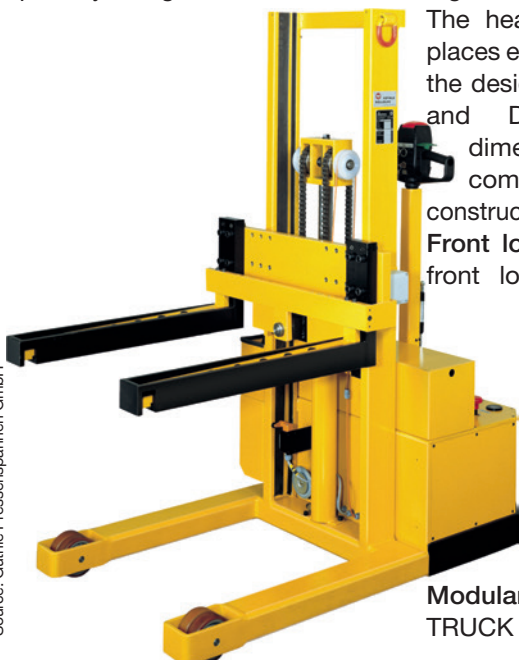

Source: Güthle Pressenspannen GmbH



**MEASURING INSTRUMENTS**

**Givi Misure Pvt Ltd**  
www.givimisureindia.com  
Hall 3A, Booth K-101

## When Technical Matters

Vasant B Vibhute, MD, Givi Misure, reveals reasons to participate in IMTEX FORMING 2020.

Givi Misure Pvt Ltd mainly focuses on metal forming machines. "That is why IMTEX FORMING 2020 and Tooltech 2020 is the perfect platform to display our products to various customers and industries," says Vibhute. The company's new products on display are the self-aligned optical scales, magnetic scales, rotary encoders, digital readouts, and position controllers.

**Focus on R&D**

For Givi Misure, smart manufacturing is the future for

industries but implementation in India may take a while due to limited resources. The economic crisis of India cannot last long, just like the ups and downs in the machine tool industry. However, he believes that this industry has a strong foundation on technical and marketing aspects and this recession should be temporary. He shares that they want to attract customers who are interested in metal forming machines, need products for support maintenance, and who are oblivious of the brand. The company conducts its business mainly in SAARC countries and India. "Our R&D is in Italy, and the R&D here mainly produces mechanical components. We invest about 7 percent of our turnover in R&D," he sums up.



Source: Magic Wand Media

**ROBOTIC SYSTEMS**

**Malles Automated and Robotic Systems Pvt Ltd**  
www.mallesautomation.com  
Hall 2A, Booth A-109

## Smarter Ways to Manufacture

Malles Automated and Robotic Systems believes that advancement in technology is the only way to industrial growth.

As a robotic systems integrator, this is Malles Automated and Robotic Systems' third time at IMTEX. The company is showcasing 'Made in India' industrial robots from MCI Robotics, which is the only Indian robot manufacturer to make and sell 6-axis Articulated type, 4-axis Scara type, and 4-axis Delta type robots. It is also launching India's first 12-axis robotic system from MCI Robotics.

**Robotics is the way**

"Manufacturing has to become smarter so we can increase productivity, quality, efficiency and revenue. Robotics is one of the most advanced technologies available now and when you couple that with AI and vision you get a superior self-learning and correcting system," says Harish Chandraprakasam, Director, Engineering & Operations, Malles Automated and Robotic Systems. Metal Forming is a ₹2500 crore industry in itself. It is a major contributor to many other industrial sectors. There is a clear awareness that to be competitive in this already competitive market one has to utilise advance technologies like robotics. The demand for such technologies is only likely to increase, says Chandraprakasam.



Source: Magic Wand Media

**VACUUM TECHNOLOGY**

**Schmalz India Pvt Ltd**  
www.schmalz.com  
Hall 3A, Booth A-127

## Array of Solutions

Saju Mathew Jacob, GM, Projects, Schmalz India Pvt Ltd believes that IMTEX is a good environment to discuss customers' problems and provide them solutions.

Across the globe, Schmalz has built a reputation in material handling using vacuum technology. The company has been a leading player and spends more than 8.5% of its turnover in R&D to stay ahead of the times for offering the best to customers.

**On Display**

At the company's booth the following are at display - Schmalz tooling system SXT for automotive industry; Robot set ECPBi for ready-to-connect robot set for light weight robots and Cobots based on Intelligent electrical vacuum

generator; Matrix Plate for clamping flat work pieces with flat undersides on CNC machining centers for aerospace industry and Vacuumaster for sheet metal handling for feeding sheets to Laser cutting machines.

**Embedded with technology**

The company has developed vacuum technology for the digital factory. Industry 4.0 is made possible only by transparent process and data. "The Intelligent vacuum components from Schmalz gather data from the process and turn it into insights. This transparency offers advantages in all phases of a product lifecycle: from fast integration of the components through the efficient operation to the complete monitoring of the process. Early fault detection and timely, predictable maintenance ensure maximum system availability," says Jacob.



Source: Magic Wand Media

**DIE AND MOULD SPOTTING PRESSES**

**Millutensil SRL**  
www.millutensil.com  
Hall 3A, Booth A-117

## Pressing Matters

Millutensil spotting presses come in two series: BV and MIL.

Millutensil is a worldwide leader in the production of die and mould spotting presses, providing safe, ergonomic, accurate and easy-to-use technologies to help streamline the checking and testing of moulds and dies.

Millutensil spotting presses come in two series: BV and MIL with platen sizes varying from a minimum of 780x660mm to a maximum of 4000x3000mm.

All operations are managed via the control panel, which controls all manoeuvres performed by the operator by means of a Siemens touch panel.

Parallelism between platens is monitored by means of a device that measures the position and parallelism of the upper platen. The company's spotting presses can also be equipped with a wax injection unit: a special hot wax can be injected into the die/mould in order to check the shape and size of the part. A hydraulic ejection unit located in the middle of the lower platen also helps in fine-tuning the system, ejecting the part from the die/mould. Thanks to the auxiliary cylinders control unit, it is possible to test movements inside the dies/moulds by moving the hydraulic cylinders driving the die/mould inner slides.

The final testing of the mould is very important to guarantee its quality.

Millutensil is present at IMTEX FORMING 2020 with its organization, ITC - Italian Technology Center (Pune).



Source: Millutensil SRL



**SHEET METAL FORMING**

**LASCO Umformtechnik GmbH**  
www.lasco.com  
Hall 4, Booth A-126

# Reaching Out

With India teeming with opportunities, it is an important market for global machine tool companies, believes LASCO.

“India is an important sales market for LASCO as well as for all globally active machine construction companies,” says Jochen Guennel, Sales Director, LASCO Umformtechnik GmbH. The company is presenting its new developments: LASCO aluminum forging line, virtual commissioning, multi-axial presses, and remote assistance system.

**Remote Assistance System**

The Remote Assistance System, displayed at IMTEX FORMING 2020 represents the technically

superior alternative to conventional means of communication. Video stream and Smart Glasses enable bidirectional image and sound transmission from the first-person perspective as well as fast and direct troubleshooting by the technician on site. The virtual support by a LASCO expert during the execution of the individual work steps significantly increases the quality of the measure.

“The introduction of digitization in forming technology has created many new tasks, which have led to new business fields in machine tool and plant engineering. Topics such as virtual commissioning and the Remote Assistance System have been driven forward by LASCO, and we are now in a position to generate added value for customers through these service offerings,” sums up Guennel.



Source: Magic Wand Media

**MANUFACTURING PLATFORM**

**Chizel Prints Manufacturing Pvt Ltd**  
www.chizel.io  
Hall 4, Booth A-152

# Connecting Manufacturers through Cloud

Chizel Prints Manufacturing has come up with a unique platform to enable suppliers and manufacturers connect.

Chizel is a user-friendly manufacturing platform wherein a buyer can upload the design and manufacturing requirements of the custom parts. The company uses its proprietary engine to identify the most optimum cost and turnaround time based on customer specifications. To find the best cost and timelines, the cloud platform searches for potential suppliers from its network and invites them to bid. The right sourcing partner is identified based on parameters like complexity, quality expectations, turnaround time and others.

**Network of manufacturing shops**

It uses its proprietary Reverse Bidding algorithm where it identifies right manufacturing partners with idle capacity. Partners, depending on their availability, quote their price. All of this allows the companies to place orders for suitable custom parts at the click of a mouse. The entire process is closely monitored to ensure that customer gets the right quality product at the right time. The status of the order is visible 24/7. Thus, giving the customers real time tracking at various stages, bringing about high levels of transparency. The manufacturing verticals include CNC machining, sheet metal fabrication, 3D printing, metal casting and silicone molding. A wide variety of cutting-edge manufacturing processes are already accessible through the platform.



Source: Magic Wand Media

**SMART WELDING**

**ETA Technology Pvt Ltd**  
www.etatechnology.in  
Hall 2A, Booth A-112

# Setting new benchmarks

Anil Purohit, Director – Sales and Marketing, ETA Technology Pvt Ltd shares in detail about the innovative technologies the company is presenting at IMTEX FORMING 2020.

When you are counted among the world leaders in design and manufacturing of friction welding and electrical upsetting (metal gathering) machines, your presence at the show becomes more important. Little wonder, the company’s portfolio also includes special purpose machines, assembly machines and machines for simulation and testing.

**New on show**

**400kVA Metal Gathering Machine**—These machines offer a near zero rejection, a configurable bulb shape and vertical configuration to save

precious floor space. The portfolio includes machines from 20kVA to 3000kVA.

**6Ton SMART Friction Welders:** This Industry 4.0 enabled machine ensures a weld orientation within +/- 0.5°, output job length control, clamping accuracy within 30 microns, and provides cloud-based metrics.

**4T Stir Welding Machine:** Friction stir welding is a relatively new solid-state joining process and is useful for joining high strength aluminum alloys and other low melting metallic alloys. Applications include railway coaches, aerospace, plate heat exchanger and even mundane processes like shuttering for roof concrete.

**Dynamic force exciter:** This tool helps to identify chatter in machine tools which is caused by a weak element in the structural chain.



Source: Magic Wand Media

**GRINDING**

**Grind Master Machines Pvt Ltd**  
www.grindmaster.co.in  
Hall 4, Booth C-104

# Looking Ahead

Grind Master Machines considers IMTEX FORMING as the biggest platform in India to showcase the latest technologies in sheet metal industry and has never missed a single show since its inception.

Mohini Kelkar, Director - Business Development, Grind Master Machines Pvt Ltd, says with a sense of pride that the company has been an active player in the show since the beginning. “The growth of Grind Master happened with the show’s growth. For this edition, we are showcasing our newly developed next-gen grinding, deburring and finishing technologies for flat components and hard metals which are in demand by automotive, defence, aerospace and metal sector,” she says.

**What to expect**

Grind Master is displaying Precision Deburring Machine for flat components and one Deburring, Grinding, Slag Removing and Edge Rounding Machine for Plasma, Laser Cut, Punched and Fine Blanked Parts from Timesavers Netherlands. It is also showcasing the next-gen deburring technology from its partner, Timesavers Holland. These are meant for aerospace components and hard metals like stainless steel, molybdenum, titanium and many more, and heavy slag grinding technology using Hammer Head.

Apart from that, the company is displaying Metal Spinning and Flow Forming Technologies in strategic Partnership with MJC Engineering, USA.



Source: Magic Wand Media



**ENERGY EFFICIENT SOLUTIONS**

**Fluid Logic Systems Pvt Ltd**  
www.systemshydraulics.com  
Hall 3A, Booth B-123

## Bright Solutions

PC Lakhani, CEO, Fluid Logic Systems Pvt Ltd, has smart solutions for press manufacturers. The company and its partner Voith Germany offer sheet metal solutions that are highly reliable, efficient and innovative.

According to Lakhani, when a manufacturer has highly efficient solutions that are Industry 4.0 ready, the scope of partnership increases to provide a complete close loop system and information with minimum power consumption and maintenance. The advanced technologies will have better product and delivery situation.

Hence, it is no surprise that the company is exhibiting energy efficient solutions for press manufacturers i.e. servo pump technology to help customers reduce losses and heat generation and minimize power consumption.

“Similarly, for assembly technology in automotive plants for sub-assemblies, we are also exhibiting CLDP i.e. hydroelectric axis which has high performance without valve technology. The cylinder is directly driven in to and fro motion through pump with all desired accuracy of force as well as position. We are offering a demo at our booth,” says Lakhani.



Source: Magic Wand Media

**SMART PRESSES**

**InDeutsch Systems Pvt Ltd**  
www.indeutsch-systems.in  
Hall 4, Booth B-143

## Poised for Success

Praveen Bhajanawale, Manager, Sales, InDeutsch Systems Pvt Ltd (ISPL), on standing out in a competitive market

InDeutsch Systems maybe a recent entrant at IMTEX FORMING but is making waves. The company has launched Rexroth's new smart press this year, which is a pre-integrated electromechanical cylinder with Servo, HMI and industrial PC. It has approximately 100 preprogrammed pressing applications with graphs for “bar vs distance” etc.

**Smart moves**

ISPL believes that Smart Press is an excellent product that will cost almost half of what other competitors are charging at present with similar capabilities and will change the pressing industry dynamics.

Some of the new product launches are:

- Rexroth Smart Press – Integrated EMC, Server, HMI and PC with good graphs
- Bosch Phantom – Completely new game changing IOT platform for SMEs
- Bosch Rexroth IOT Kit
- Bleichert – Gantry and 7<sup>th</sup> Axis system
- Emerson Asco and Aventics portfolio enhancements



Source: Magic Wand Media

**INDUSTRIAL VEHICLES**

**AMIDC Automation Technologies Pvt Ltd**  
www.atimotors.com  
Hall 4, Booth B-144

## A Guided Tour

Dr S Rengarajan, Fellow - Senior Research Scientist, AMIDC Automation Technologies Pvt Ltd, is keen to talk about Sherpa to every visitor and how processes at their plants can see quick TAT.

AMIDC Automation Technologies a.k.a. Ati Motors is showcasing an electric industrial cargo autonomous vehicle, Sherpa, which is the first of its kind in India. It has been built using robotics, deep learning and AI. Dr Rengarajan says, “Many exhibitors are interested in deploying Sherpa for automating movement at their facilities. As metal forming also involves heavy material movement, we are showcasing this technology.”

The company is displaying the self-driving nature of Sherpa. The driverless feature of the vehicle is achieved by processing the data from sensors that see the surroundings. Sherpa with a three-

wheeler tadpole design having dimensions 90cm x 176 cm x 100cm (WxLxH) and aided by sensors, LIDAR, a camera and host of instruments, will navigate once it has been taught/trained about the environment. As a self-driving vehicle, Sherpa can detect obstacles and stop at a safe distance. On its flatbed, Sherpa can carry 150kg payload or pull about 700kg of payload using trolleys.

**Quick movement**

Ati Motors believes that the entire chain of order-to-production activity should be automated wherever possible. Material movement forms an inseparable part of any manufacturing facility. A unique feature of Sherpa is that it can operate both indoors and outdoors. Another feature is that it can operate in poor light as it uses LIDAR.



Source: Magic Wand Media

Source: AMIDC Automation Technologies Pvt Ltd

**LASER WELDING SYSTEMS**

**SLTL Group**  
www.sltl.com  
Hall 4, Booth B-110

## NOVA Addresses Multiple Solutions

The SLTL Group's laser system, NOVA is designed to perform specialised tasks for the industry.

The laser welding systems from the SLTL Group deliver the precision and efficiency required for large-scale industrial applications. The new from the Group's factory is NOVA, a compact, portable, and ergonomically designed laser system with an innovative user-friendly concept with the capability to weld extremely small parts and fine structures to larger ones, and achieve strong, visually flawless seams.

These features made the system win the FIE Foundation Most Innovative Award at IMTEX CUTTING 2019.

Its fast precision linear motion, also with a new control concept, continues to ensure the greatest

possible production throughput. The modular construction of the system and standardized interfaces allow for an easy integration – also in already existing systems. The approved beam guiding systems ensure a safe operation under industrial conditions.

**More than laser welding**

With NOVA, it is possible to look beyond the obvious laser welding. It is designed to perform tasks like Drilling, Annealing and Hardening. The SLTL Group's NOVA uses its own proprietary laser micro-drilling systems, sub-contract micro-drilling and process development services for microhole production and R&D. The in-house R&D team at SLTL Group has designed NOVA to be suitable for bi-metal welding. This versatility adds an advantage to many industries and produces never before imagined components and concepts.



Source: SLTL Group



**INTERNATIONAL VIEWPOINT**

**VDW**  
www.vdw.de  
Hall 3A, Booth C-104

# Strong Growth Ahead

**Dr Wilfried Schäfer, Executive Director, VDW (German Machine Tool Manufacturers' Association), has a good overview of how India and Germany can work together to improve trade between the two countries.**

The German Machine Tool Manufacturers' Association (VDW) has been a staunch supporter of the Indian market. Dr Wilfried Schäfer says, "Germany is one of the most important business partners for Indian industry. In 2018, Germany supplied one tenth of India's machine tool imports, ranking fourth among the most important suppliers behind Japan, China and South Korea. This makes Germany the only non-Asian country among the top five suppliers." For long, India and Germany have been friendly partners in the machine tool business, and forming technology is an important part of production technology. In Germany, it accounts for about a quarter of the total production of machine tools, in India it accounts for around a tenth. IMTEX FORMING is perhaps the main Indian trade fair in this field. For this reason, VDW has traditionally been involved in this trade fair organising a common German participation. The German market is also open to imports. In 2018, Germany absorbed six percent of Indian

exports, putting it in the third place of the most important markets for Indian machine tool suppliers behind China and the USA. In the first three quarters of 2019, German manufacturers exported machinery worth around €150 million. Currently, laser technology, bending and punching machines as well as presses are in particular demand.

**What's coming**

Ask him on the metal forming technologies from Germany that can help present Indian manufacturing sector and he says, "When the underlying standards of umati will be finally published in summer 2020, they will be available worldwide free of charge. All machines equipped with these standards have a uniform data structure, which makes it easy to integrate them into customer-specific IT ecosystems. The benefits and added value resulting from the accessible data are in the hands of the machine users." Citing another example of where intelligent use of data brings benefits for the user is energy



Source: VDW

“Smart technologies enable tool manufacturers to generate added value on the one hand, and to know their own products better on the other hand. Primarily, data obtained from machines creates greater transparency with regard to efficiency and productivity.”

**Dr Wilfried Schäfer**  
Executive Director  
VDW (German Machine Tool  
Manufacturers' Association)

efficiency using forming technology. Energy efficiency at the component, i.e. the unit cost, still plays a dominant role for customers. But since typically the users of larger presses are large companies, they do consider the environment. Data can now be used to analyse where energy is wasted unnecessarily, and on this basis, it is possible to optimise and increase efficiency. These results, for example, in the use of more controlled hydraulic pumps that can be regulated to the exact point and sometimes even make valves superfluous.



**HIGHLIGHTS**

- 600+ exhibitors
- Exhibitors from 26+ countries
- 500+ live demos
- Focus on Additive Manufacturing and Industry 4.0
- Over 33,000 sq mt of exhibition space
- International Seminar on Forming Technology
- i2 Academia Pavilion: an event for academia and industry to interact and explore possibilities for tie-ups
- Connect: an awareness programme on machine tool industry
- Reverse International Buyer-Seller Meet: an interaction platform for machine

**Ordnance Factory Board Delegates @ BIEC**



Source: IMTMA

Indradev Babu, President, IMTMA (fifth from left); A.K.Agarwal, IOFS, Senior Deputy Director General, Ordnance Factory Board (seventh from left); V Anbu, Director General & CEO, IMTMA (third from right)

**Delegates**



Source: IMTMA

H Basavarajendra, I.A.S., CEO & EM - KIADB and CEO - TMTP (fourth from left) visited IMTEX FORMING 2020 & Tooltech 2020 with other officials from Tumakuru Machine Tool Park (TMTP)

**A BIG Thanks to all of you for the Opportunity to GROW with You!**



Concurrent Show



International Exhibition of Dies & Moulds, Forming Tools,  
Machine Accessories, Metrology and CAD / CAM

ePaper



Trade Mark **SHOWDAILY** is  
Owned by Magic Wand Media Inc





**ENGINEERED ALLOYS**

**AMPCO METAL India Pvt Ltd**  
www.ampcometal.com  
Hall 3A, Booth L-103

# AMPCO®21 as gripper jaws on pilger mill

An interesting account of how benefits of AMPCO®21 over brass material as gripper jaws used on a pilger mill for the production of stainless steel seamless tube were recognized.

The trial comparing AMPCO®21 gripper jaws against existing brass gripper jaws was conducted at a highly reputed stainless steel seamless tube manufacturer in Umbergaon. AMPCO METAL supplied one set (3 pieces) of finished machined gripper jaws in AMPCO®21 material as per the drawing. This was put to use on June 20, 2018 on SMS pilger mill. The gripper jaws were removed from the pilger mill on July 24, 2018, after being effectively used for 27 days during this period. The observation was a smooth wear pattern of AMPCO®21 jaws as on July 24. AMPCO®21 gripper jaws showcased much better results than the earlier used brass jaws.

**Observations**

Following are the observations from the user:

**Quality improvements:**

- No rejections; no clamping marks were observed on tubes using AMPCO®21 jaws.

**Life of the jaws:**

- Per day production on one SMS pilger mill is approx.

1 km of tube. AMPCO®21 gripper jaws were used for 27 days, producing approx. 27 km of tube.

- Jaws made in brass produce approx. 5 to 6 km of tube and last for approx. 6 days.
- Brass jaws show very rough surface with material displacement after complete usage. Whereas AMPCO®21 jaws worn out in a regular pattern for 0.3 mm with a smooth surface finish.

**Productivity improvement:**

- The entire mill has to be stopped to change gripper jaws, which takes approx. 45 to 60 mins.
- In case of brass jaws, mill has to be stopped after every 5 to 6 days for this replacement.
- Using AMPCO®21 jaws, approx. 4 to 5 hours can be used for additional production.
- Operator has to do lesser adjustments because of lesser wear rate.

**Productivity enhancement through AMPCO®21 jaws**

Production / day = 1000 m  
Production / hour = 41.6 m

**Comparison: Considering effective time of 27 days / total usage of AMPCO®21 gripper jaws:**

Parameters	Gripper jaws in AMPCO®21 material	Gripper jaw in regular material (brass)
Life	Total life observed was 27 days (producing approx 27 km of tube)	Total life of existing jaws was 6 days (producing approx 6 km of tube)
Equipment downtime	No downtime in 27 days	1 hour downtime every 5 to 6 days
Production loss	No loss of production	Considering 1 km tube production in 1 day, production loss was approx 41.6 m every 5 to 6 days
Rejection	No clamping marks are observed on the tube — therefore no rejection	Worn out jaws give clamping marks on the tube because of irregular / worn out surface on jaws

Production loss due to change over time of existing brass jaws in 5 hours = 210 m per month

Hence, AMPCO®21 jaws led to an additional production of

210 m of tube per month, operator intervention for regular equipment adjustments reduced by great extent, and equipment efficiency usage increased by 5 hours.



Gripper jaw made in brass material

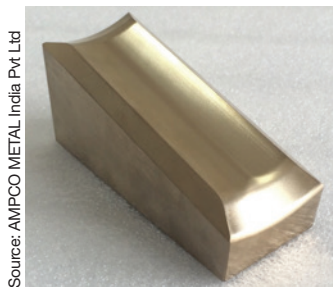

Gripper jaw made in AMPCO®21 material

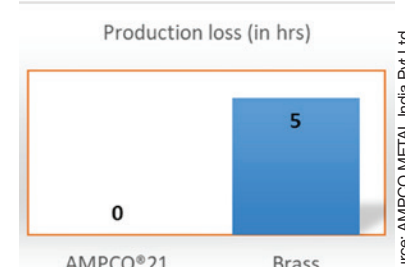
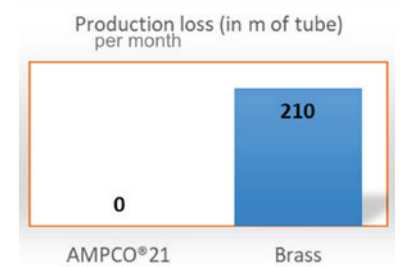
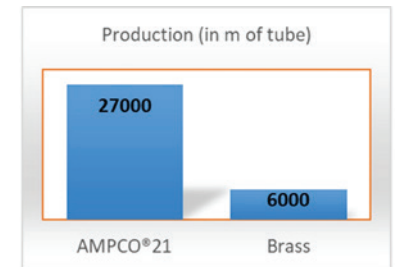
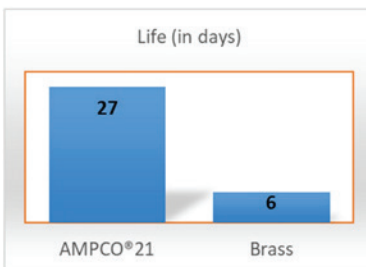
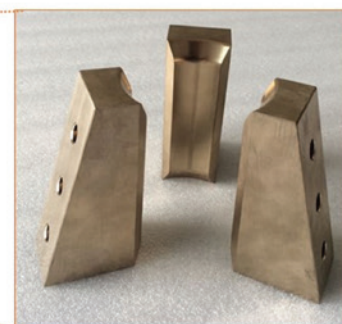

Source: AMPCO METAL India Pvt Ltd

Source: AMPCO METAL India Pvt Ltd

Source: AMPCO METAL India Pvt Ltd

Source: AMPCO METAL India Pvt Ltd

Source: AMPCO METAL India Pvt Ltd



**VISITORS' VIEWS**



Source: Magic Wand Media

“IMTEX FORMING 2020 is a wonderful platform displaying a wide variety of the latest technologies. Along with global recession, every country has its own crisis but it's heartening to see that the Indian government is in the process of reforming policies in areas such as easing Foreign Direct Investment clearance systems, reducing business loan interest etc. I have come here to gauge the buying interest of the people. I am yet to come to a conclusion.”

**B Sesaiah**  
 Director - Business Development  
 Euro Gulf Technologies (FZC)  
 Sharjah, UAE



“I supply components to the Railways and needed a few automatic welding machines for quality improvement. For SS, working Laser is the best method. I never expected to see so much on Laser technology all at one place. I have found a source for pipe cutting laser. Also, now I know the machines that can cut even 100 mm thick SS plates easily. I am glad to have come here.”

**G Panchanadan**  
 Proprietor  
 Best Stamping & Forging  
 Chennai



“I have come to explore the cutting-edge technologies in the field. The expo, I believe, is the perfect place to gain knowledge and learn about new trends in the industry. It's been worthwhile coming here.”

**Shyam Singh**  
 Quality Head  
 Everest Blowers Pvt Ltd  
 Haryana



“After having missed IMTEX FORMING the last two times, I had made it a point to somehow make it to this edition. As expected, I got to catch up on the latest entrants to the field, the new trends and technologies, which otherwise was difficult for me to have known. We are into sheet metal and everything needed by us is available here. It's all available online but the expo gives us an opportunity to closely have a feel of them. I am happy I could come.”

**Abhay Paranjpe**  
 Director  
 Aura Laserfab Pvt Ltd



“I had a stall at IMTEX CUTTING last year. This show being dedicated to the forming industry, I have just come to see the types of machines being showcased. The number of global companies keeps increasing every year, which is highly positive. That said, I again would be an exhibitor at IMTEX next year. The current edition has been very well arranged.”

**Sridhar Appaji**  
 Director  
 Control Technics

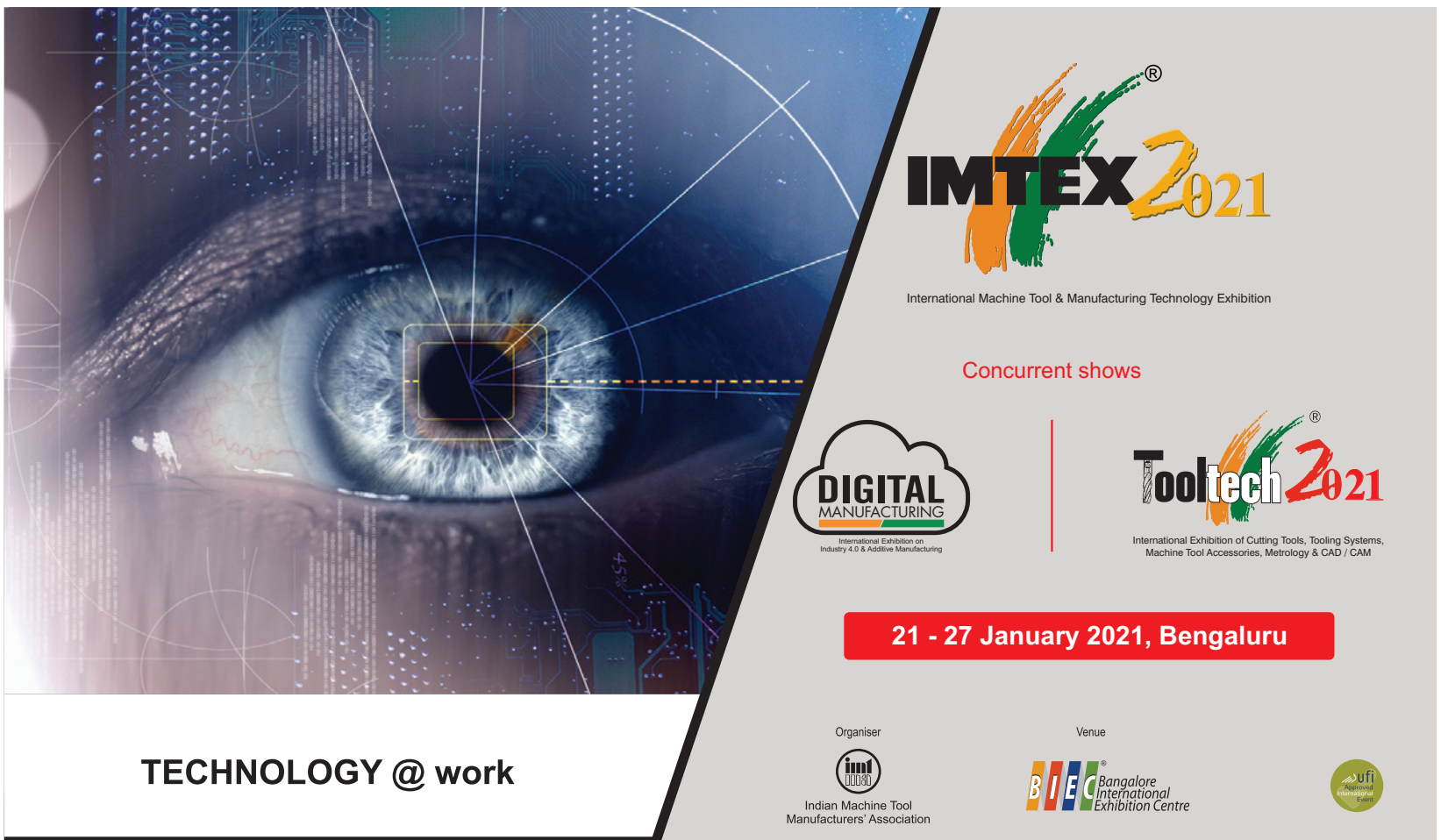

**IMTEX 2021**  
 International Machine Tool & Manufacturing Technology Exhibition

Concurrent shows

**DIGITAL MANUFACTURING**  
 International Exhibition on Industry 4.0 & Additive Manufacturing

**Tooltech 2021**  
 International Exhibition of Cutting Tools, Tooling Systems, Machine Tool Accessories, Metrology & CAD / CAM

**21 - 27 January 2021, Bengaluru**

Organiser:  Indian Machine Tool Manufacturers' Association

Venue:  Bangalore International Exhibition Centre



**TECHNOLOGY @ work**



QUALITY MATTERS

www.SLTL.com

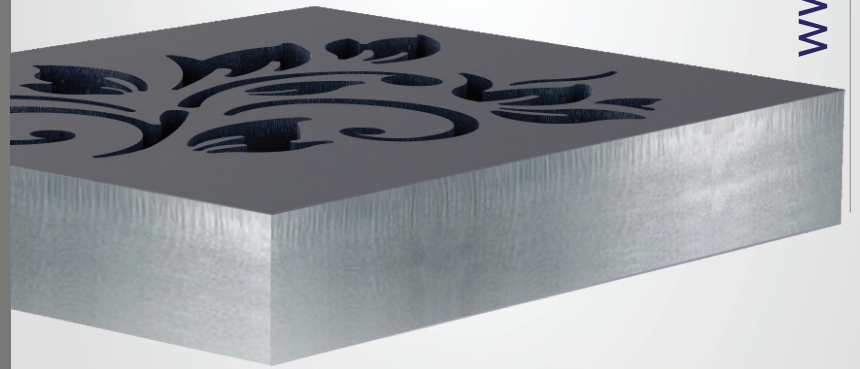
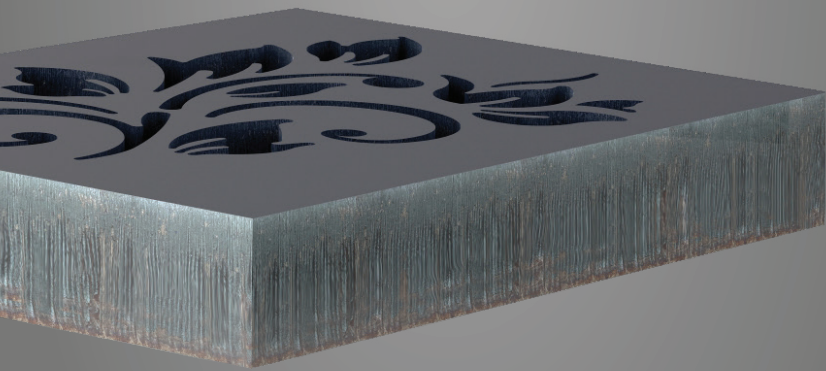

WHAT'S YOUR CHOICE?

“ High speed Fiber Laser Cutting Systems designed to attain ***Ultimate Quality*** with ***Unprecedented Precision***. “

VISIT US @  
HALL : 4 | STALL : B-110

SLTL Group received Best Brand Award by Economic Times for its contribution to key transformations in the industry. We dedicate this success to our valuable customers.

